

Multi 9



PRD surge arresters

Surge arresters are designed to protect electrical equipment against atmospheric overvoltage's (lightning) and/or power surges (switching overvoltages). The choice of a surge arrester is based on the sites level of exposure to overvoltage's and the assessment of the consequences of disturbances on loads to be protected

Operation

A surge arrester ensures the run-off of a current due to an overvoltage above a permissible voltage threshold level (U_c)

- > Stand-by; when no over voltages are present, the surge arrester has high impedance which does not effect the installation
- > In operation; the surge arrester is triggered and runs a high impulse current to the ground for the length of the electrical disturbance. It significantly limits the voltage on load terminals to a given protection level (U_p)
- > Cartridges end of life is indicated by a red mechanical indicator or through an auxiliary contact. It should be immediately replaced.

Advantages

- > Certified co-ordination with Schneider Electric's Multi 9 circuit breakers provide complete safety in the event of a short circuit
- > PRD withdrawable surge arresters allow fast replacement of damaged cartridges
- > Matching surge protection bases ensure removable cartridges can be upgraded with higher kA (I_{max}) cartridge ratings
- > PRD "r" surge arresters have an auxiliary contact for remote indication
- > AS/NZS3000/2007 recommends the use of surge protection. Protect home theatre systems, LCD screens, washing machines, microwaves, computer networks, data servers, industrial equipment including PLC's providing essential services that are crucial to today's business operational productivity



> The range



1P



1P + N



3P



3P + N



Spare cartridges

Implementation

- > High I_{max} (kA) rated surge arresters give a higher level of protection and a longer service life
- > External disconnection of the surge arrester must be ensured by Schneider Electric's Multi 9 circuit breaker to protect against short circuits
- > Additional built in end of life thermal disconnection is provided in each surge arrester
- > Use 1P or 3P surge arresters with installations where the MEN link is installed
- > Use 1P + N or 3P + N surge arresters with installations where the MEN link is removed
- > Preferable to install surge arresters upstream from RCD devices

Technical data

- > Operating frequency 50/60Hz
- > Operating voltage 230/400V AC
- > Permanent operating current I_c < 1mA
- > Response time < 25ns
- > End of life indication
 - White; in operation
 - Red; end of life replace
- > Auxiliary contact NO NC 250V 0.25A
- > Connection via tunnel terminal 2.5 to 35mm²
- > Operating temperature -5 to +40°C
- > Standards IEC61643-1 Type 2

Example

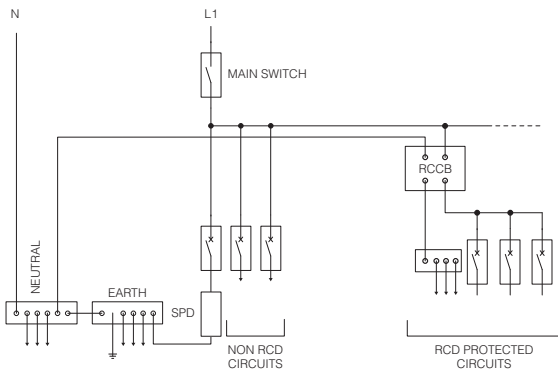

Lightning density

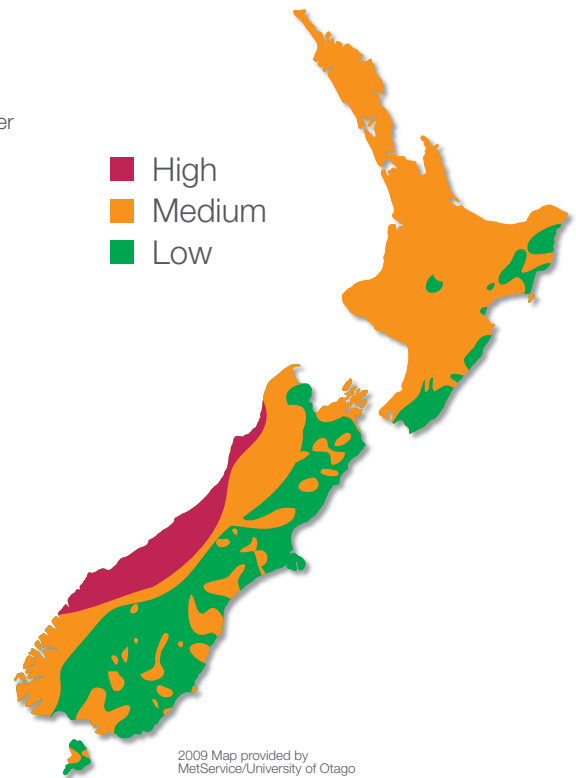

Understand increased risks

Lightning is attracted by high points that conduct electricity. They can be:

- > natural: tall trees, mountain crest, wet areas, ferrous soil
- > artificial: chimney, aerial, pylon, lightning conductor.
- > Indirect effects can be incurred within a fifty metre radius around the point of impact.

Location of the building	Surge Arrester	No. of poles	Width in mod. of 9mm	I _{max} kA	Network rated voltage V	Cat no.	Dedicated disconnecter (MCB) Rated breaking capacity to match installation e.g. 4.5kA, 6.0kA, 10kA.
Refer to lightning density chart & select high kA rated surge arresters when increased risks are present  In an area where there is a particular hazard (pylon, tree, mountainous region, mountain crest, wet area or pond).	"r" remote auxiliary contact						
	PRD120r - recommended for high risk installations						
	PRD120r	1P	4	120	230	16450	Multi 9 C60 50A C curve
	PRD120r	3P	12	120	230/400	3x 16450	Multi 9 C60 50A C curve
	PRD65r						
	PRD65r	1P	2	65	230	16556	Multi 9 C60 50A C Curve
	PRD65r	1P+N	4	65	230	16557	Multi 9 C60 50A C Curve
	PRD65r	3P	6	65	230/400	16443	Multi 9 C60 50A C Curve
	PRD65r	3P+N	8	65	230/400	16559	Multi 9 C60 50A C Curve
	PRD40 - recommended for medium risk installations						
	PRD40r	1P	2	40	230	16561	Multi 9 C60 40A C Curve
	PRD40	1P	2	40	230	16566	Multi 9 C60 40A C Curve
PRD40r	1P+N	4	40	230	16562	Multi 9 C60 40A C Curve	
PRD40	1P+N	4	40	230	16567	Multi 9 C60 40A C Curve	
PRD40r	3P	6	40	230/400	16445	Multi 9 C60 40A C Curve	
PRD40	3P	6	40	230/400	16568	Multi 9 C60 40A C Curve	
PRD40r	3P+N	8	40	230/400	16445	Multi 9 C60 40A C Curve	
PRD40	3P+N	8	40	230/400	16569	Multi 9 C60 40A C Curve	
PRD20 - recommended for low risk installations							
PRD20	1P	2	20	230	16571	Multi 9 C60 25A C Curve	
PRD20r	1P+N	4	20	230	16672	Multi 9 C60 25A C Curve	
PRD20	1P+N	4	20	230	16572	Multi 9 C60 25A C Curve	
PRD20	3P	6	20	230	16447	Multi 9 C60 25A C Curve	
PRD20r	3P+N	8	20	230	16674	Multi 9 C60 25A C Curve	
PRD20	3P+N	8	20	230	16574	Multi 9 C60 25A C Curve	
Spare cartridges							
C120						16457	
C65						16681	
C40						16685	
C20						16687	
C neutral						16691	

Owing to changes in standards and equipment, the characteristics given in the text and images in this document are not binding until they have been confirmed with us.

Schneider Electric New Zealand Ltd.

Customer Care Free call 0800 652 999

www.schneider-electric.co.nz

©Schneider Electric 2008